

NOTE "B" FLOOR CONSTRUCTION
 3/4" GYPSUM FLOOR UNDERLAYMENT OVER 23/32" APA RATED STURD-I-FLOOR EXPOSURE 1 SHEATHING PLACED PERPENDICULAR TO SUPPORTING MEMBERS. GLUE-NAIL WITH 8d RING-OR SCREW SHANK NAILS AT 6" ON-CENTER AT ALL PLYWOOD EDGES AND 12" ON-CENTER AT INTERMEDIATE SUPPORTS. SEE GENERAL NOTES ON DWG. S1.1
 TOP OF GYPSUM ELEVATION: +10'-9" @ 1ST, +21'-6" @ 2ND, +42'-3" @ 3RD, +53'-0" @ 4TH

FOURTH FLOOR FRAMING PLAN
 SCALE: 1/8" = 1'-0"

WALL STUD SCHEDULE					
FLOOR	EXTERIOR ROOF BEARING WALLS ONLY	EXTERIOR BEARING WALLS	INTERIOR BEARING WALLS	CORRIDOR WALLS	PROJECTING MECH. ROOM WALLS
4TH	2x6 @ 16" O.C.	2x6 @ 16" O.C.	2x6 @ 16" O.C.	2-2x4 @ 16" O.C.	2x4 @ 16" O.C.
3RD	2x6 @ 16" O.C.	2x6 @ 16" O.C.	2x6 @ 16" O.C.	2-2x4 @ 16" O.C.	2x4 @ 16" O.C.
2ND	2x6 @ 16" O.C.	2x6 @ 16" O.C.	2-2x6 @ 16" O.C.	2-2x4 @ 16" O.C.	2x4 @ 16" O.C.
1ST	2x6 @ 16" O.C.	2-2x6 @ 16" O.C.	2-2x6 @ 16" O.C.	2-2x4 @ 16" O.C.	2-2x4 @ 16" O.C.
GROUND	2x6 @ 16" O.C.	2-2x6 @ 16" O.C.	3-2x6 @ 16" O.C.	2-2x4 @ 16" O.C.	2-2x4 @ 16" O.C.

WALL STUD SCHEDULE NOTES:
 1. WALL STUDS SPACED AT 16" O.C. U.N.O.
 2. DOUBLE AND TRIPLE STUDS TO BE FASTENED TOGETHER PER POST NOTE 3.

BEAM SCHEDULE			
MARK	SIZE	MARK	SIZE
B1	2 - 2 x 6	B11	3 - 2 x 6
B2	2 - 2 x 8	B12	3 - 2 x 8
B3	2 - 2 x 10	B13	3 - 2 x 10
B4	2 - 2 x 12	B14	3 - 2 x 12
B5	2 - 1 3/4" x 5 1/2" LVL	B15	3 - 1 3/4" x 5 1/2" LVL
B6	2 - 1 3/4" x 7 1/4" LVL	B16	3 - 1 3/4" x 7 1/4" LVL
B7	3 1/2" x 9 1/2" LVL	B17	5 1/4" x 9 1/2" LVL
B8	3 1/2" x 11 7/8" LVL	B18	5 1/4" x 11 7/8" LVL
B9	3 1/2" x 14" LVL	B19	5 1/4" x 14" LVL
B10	3 1/2" x 16" LVL	B20	5 1/4" x 16" LVL

BEAM NOTES:
 1. FASTEN MULTIPLE PLY BEAMS PER STRICTER REQUIREMENTS OF TYPICAL 2 & 3 PIECE MEMBER FASTENING DETAIL OR MANUFACTURER'S REQUIREMENTS.
 2. SUBSTITUTION OF MULTIPLE PLY BUILT UP BEAMS FOR BEAMS NOTED AS ONE WIDER PIECE IS NOT PERMITTED.
 3. AT 2 - 2x BEAMS IN 2x4 STUD WALLS, ADD 1/2" PLYWOOD SPACERS.
 4. AT 3 - 2x BEAMS IN 2x6 STUD WALLS, ADD 2 - 1/2" PLYWOOD SPACERS.
 5. AT 5 1/4" WIDE BEAMS IN 2x6 STUD WALLS, ADD 1/4" PLYWOOD FILLER.

JOIST AND BEAM HANGER SCHEDULE		
MARK	SIMPSON MODEL	NOTES
U1	LSSU210	TYP. @ SLOPED 2x10 RAFTERS, U.N.O.
U2	LSSU210-2	TYP. @ SLOPED 2-2x10 RAFTERS, U.N.O.
U3	LUS210-2	TYP. @ 2-2x10 AND 2-2x12 BEAMS, U.N.O.
U4	IUS2.37/9.5	TYP. @ 9 1/2" TJI 230, U.N.O.
U5	HU4.75/9	TYP. @ DOUBLE 9 1/2" TJI 230, U.N.O.
U6	IUS3.56/14	TYP. @ 14" TJI 560, U.N.O.
U7	HU414-2	TYP. @ DOUBLE 14" TJI 560, U.N.O.
U8	THA426	TYP. @ WOOD FLOOR TRUSSES, U.N.O.
U9	HHUS410	TYP. @ B7 AND B8 BEAMS, U.N.O.
U10	LSSU410	TYP. @ SLOPED AND SKEWED B8 BEAMS, U.N.O.
U11	HB3.56/11.88	TYP. @ B8 BEAMS TO STEEL BEAMS, U.N.O.
U12	HHUS5.50/10	TYP. @ B7 BEAMS, U.N.O.
U13	HGUS5.50/12	TYP. @ B18 BEAMS, U.N.O.
U14	HB5.5/11.88	TYP. @ B18 BEAMS TO STEEL BEAMS, U.N.O.
U15	HGUS5.50/14	TYP. @ B19 BEAMS, U.N.O.

HANGER NOTES:
 1. FULLY NAIL ALL HANGERS TO PROVIDE MAXIMUM HANGER CAPACITY.
 2. INSTALL ALL NAILS IN ACCORDANCE WITH MANUFACTURER'S REQUIREMENTS.
 3. INSTALL HANGERS BEFORE INSTALLING SUPPORTED JOISTS OR BEAMS.
 4. ALL HANGERS AND HANGER FASTENERS USED WITH P.T. FRAMING MUST BE ZMAX COATED OR STAINLESS STEEL.
 5. HANGERS FOR ROOF TRUSSES TO BE SIZED AND PROVIDED BY ROOF TRUSS SUPPLIER.

LEGEND	
	ON PLAN INDICATES STRUCTURAL WALLS. SEE WALL STUD SCHEDULE
	SHEAR WALL: 2x4 OR 2x6 WOOD STUDS @ 16" O.C.
	ON PLAN INDICATES HEADERS. SEE NOTES 2 & 3
	ON PLAN INDICATES HEADERS WITH OFFSET OPENING(S) ABOVE. SEE NOTES 2, 3 & 4
	ON PLAN INDICATES A SIMPSON STRONG TIE HANGER OF THE TYPE AND SIZE INDICATED IN THE JOIST AND BEAM HANGER SCHEDULE OR AS SPECIFIED BY THE TRUSS SUPPLIER AT TRUSS CONNECTIONS, U.N.O.
	INDICATES STRUCTURAL WALL TYPE. SEE WALL TYPE SCHEDULE FOR ADDITIONAL INFORMATION. USE WALL TYPE (A) TYP. U.N.O. FOR ALL EXTERIOR WALLS.
	INDICATES HOLDOWN TYPE AT BASE OF WALL BELOW FLOOR INDICATED. SEE ANCHOR TIE DOWN (ATS) AND TYPICAL DETAILS FOR ADDITIONAL INFO. ATS RUNS INDICATED EXTEND TO ONE OR MORE FLOORS ABOVE PER THE ATS RUN TYPE INDICATED.

WALL LEGEND NOTES:
 1. WALL STUDS, HEADERS, AND TYPES INDICATED OCCUR BELOW THE FRAMING LEVEL SHOWN.
 2. FOR ALL HEADERS, SEE THE HEADER SCHEDULE AND THE OPENING FRAMING DETAILS.
 3. AT BEARING WALLS PROVIDE CRIPPLE STUDS UNDER EACH JAMB AND JACK STUD GROUP BETWEEN THE WALL TOP PLATE AND THE FLOOR SHEATHING ABOVE. CRIPPLE STUDS TO MATCH THE JAMB AND JACK STUD QUANTITY INDICATED FOR THE OPENING ABOVE.
 4. PROVIDE POSTS UNDER THE UPPER FLOOR JAMB AND JACK STUD GROUPS DOWN TO THE HEADER OR THE FLOOR BELOW. SIZE OF POST TO MATCH THE JAMB AND JACK STUD QUANTITY INDICATED FOR THE OPENING ABOVE.

- FLOOR FRAMING NOTES:**
- PROVIDE SOLID HORIZ. BRIDGING AT MID HEIGHT OF ALL INTERIOR AND EXTERIOR WOOD STUD BEARING WALLS, U.N.O.
 - WFT INDICATES 18" DEEP PREFABRICATED WOOD FLOOR TRUSSES @ 16" O.C., U.N.O. W/ 2x4 MINIMUM CHORDS. SEE DRAWING S9.1 FOR ADDITIONAL REQUIREMENTS.
 - TRUSSES AND JOISTS TO ALIGN WITH THE WALL STUDS. COORDINATE TRUSS LAYOUT WITH MEP DRAWINGS AND PROVIDE ADDITIONAL FLOOR TRUSSES UNDER NON-BEARING WALLS PARALLEL TO SPAN.
 - SEE DRAWING S9.1 FOR STAIR REQUIREMENTS.
 - L1 INDICATES 4x10 WOOD LEDGER. FASTEN WITH 3/4" THREADED RODS AT 16" O.C. AFFIXED WITH HILTI HY150 SYSTEM AND 6 5/8" EMBED. AT GROUTED CMU.
 - L2 INDICATES 2 - P.T. 2x10 WOOD LEDGER, FASTENED WITH 5/8" x 6" LONG LAG SCREWS @ 8" O.C. STAGGERED. PROVIDE DOUBLE 2x10 BLOCKING AS REQUIRED.
 - P.U. ON PLAN INDICATES POST UP.
 - FOR POSTS SHOWN ON THIS LEVEL AND NOT ON LEVELS BELOW, PROVIDE POSTS IN THE SAME LOCATION AND OF EQUAL SIZE AT ALL LEVELS BELOW.
 - C1 ON PLAN INDICATES HSS4x4x5/16 COLUMN WITH 3/4" THICK "L" SHAPED BASE PLATE.
 - C2 ON PLAN INDICATES HSS4x4x5/16 COLUMN WITH A 3/4"x10"x0"-10" BASE PLATE.
 - COLUMN BASE PLATES TO BE ANCHORED WITH 4-3/4" THREADED RODS AFFIXED WITH HILTI HY150 SYSTEM AND 6 5/8" EMBED.
 - WHEN A STEEL COLUMN SUPPORTS A WOOD BEAM, PROVIDE A STEEL COLUMN CAP PER DETAIL 9 ON DRAWING S2.3.

POST SCHEDULE	
MARK	POST SIZE
P1	2 - 2 x 4
P2	4 x 4
P3	3 - 2 x 4
P4	4 x 6
P5	4 x 8
P6	2 - 2 x 6
P7	3 - 2 x 6
P8	6 x 6
P9	6 x 8
P10	3 1/2" x 3 1/2" PARALLAM
P11	3 1/2" x 5 1/4" PARALLAM
P12	3 1/2" x 7" PARALLAM
P13	5 1/4" x 5 1/4" PARALLAM
P14	5 1/4" x 7" PARALLAM
P15	7" x 7" PARALLAM

POST NOTES:
 1. PROVIDE SIMPSON AC AND ACE POST CAPS AT ALL POSTS NOTED -AC AND -ACE RESPECTIVELY.
 2. PROVIDE SIMPSON CCO AND ECCO COLUMN CAPS AT ALL POSTS NOTED -CO AND -ECCO RESPECTIVELY.
 3. ALL BUILT-UP POSTS SHALL BE GLUED AND NAILED WITH 10d COMMON WIRE NAILS PLACED AS FOLLOWS:
 A. ADJACENT NAILS SHALL BE DRIVEN FROM OPPOSITE SIDES OF THE POST.
 B. PLACE NAILS 2 1/2" FROM POST END.
 C. PLACE NAILS AT 8" O.C. ALONG POST.
 D. PROVIDE 2 ROWS OF NAILS 1 1/2" FROM THE EDGE.
 4. AT 5 1/4" PARALLAM POSTS IN 2x6 WALLS, ADD 1/4" PLYWOOD AS REQ'D. TO MATCH THE WALL THICKNESS.
 5. PROVIDE 2 STORY TALL POSTS FOR ALL LOCATIONS NOTED AS -2S AT THE INTERMEDIATE FLOOR OF THE 2 STORES.

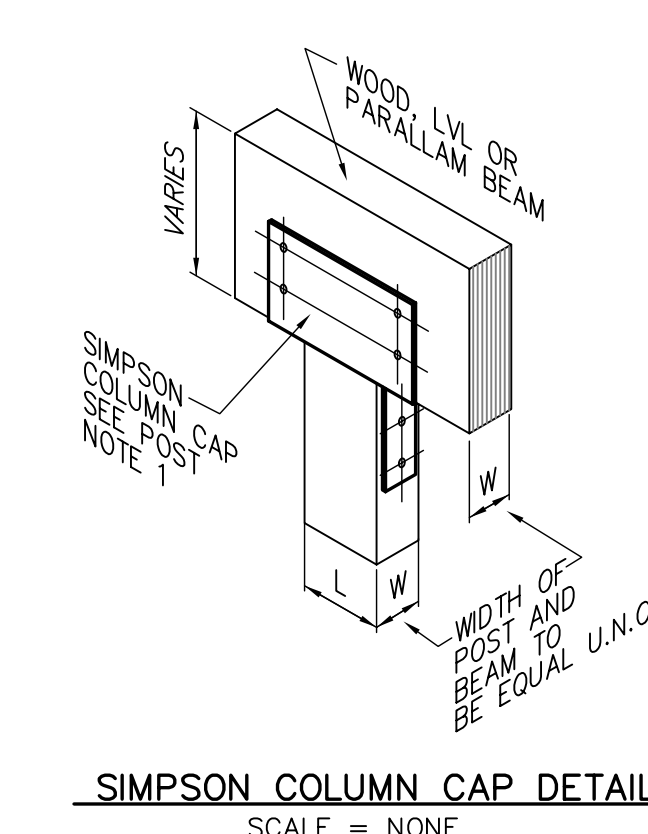

SIMPSON COLUMN CAP DETAIL
 SCALE = NONE
 NOTE: 1. CC CAP SHOWN, CCO, ECC AND ECCO SIMILAR.

Lynnfield Commons Unknown Street Lynnfield, Massachusetts	FOURTH FLOOR FRAMING PLAN
Russell Scott Steadle & Capone Architects Inc. 18 Brattle Street, Cambridge, Massachusetts 02138 • 617-661-5880 Fax 661-0613	Date: 08/31/07 0762
DM Berg Consultants P.C. Structural Engineers 570 Hillside Ave., Needham Heights, Massachusetts 02464 • 781-444-5156 Fax 444-5157	09/14/07 S4.4
Scale: 1/8" = 1'-0"	