

ALLOWABLE ATS ROD OFFSET
INSTALLATION CRITERIA

1
S2.6

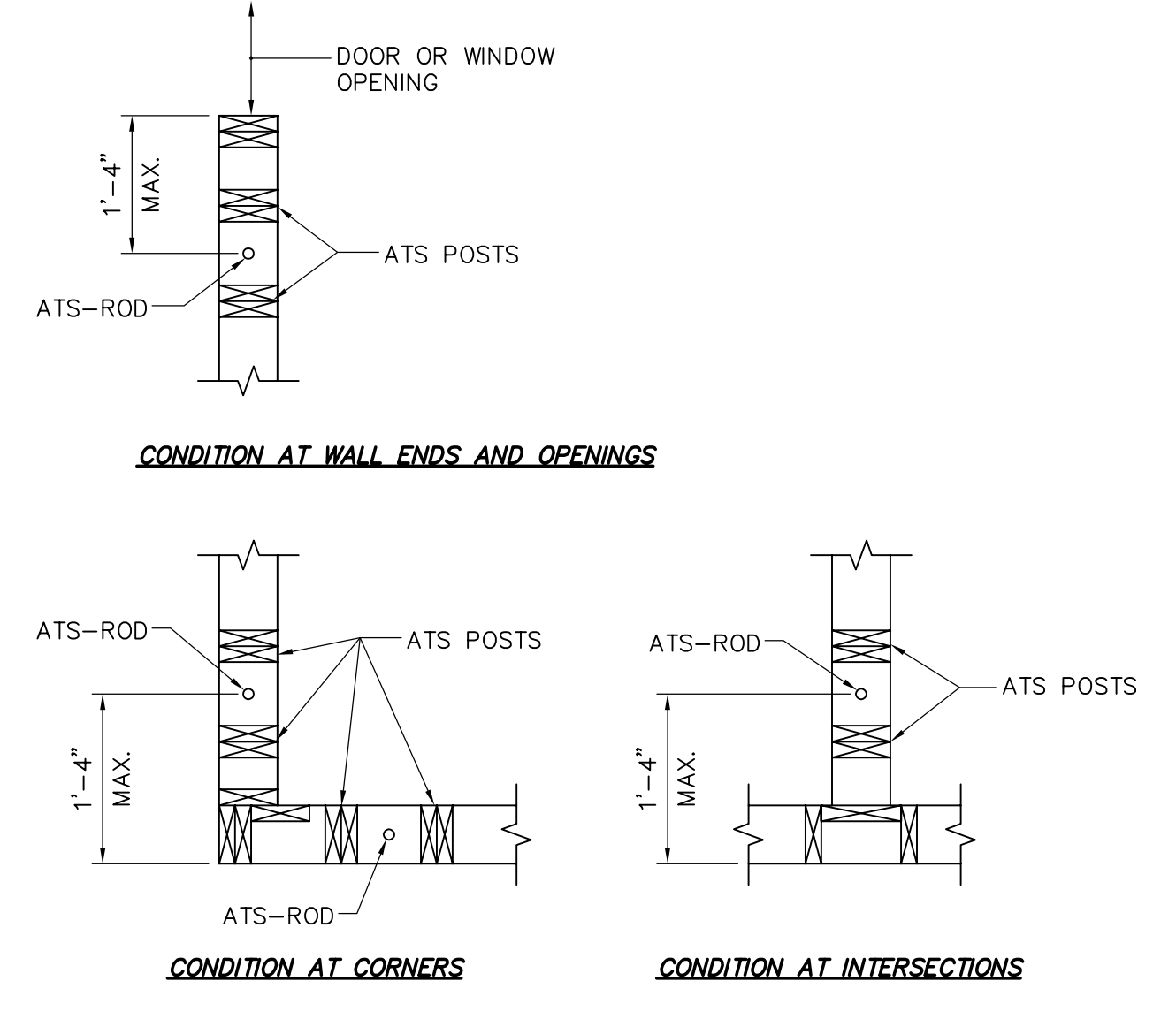

ATS ROD PLACEMENT
GUIDELINE DETAIL

2
S2.6

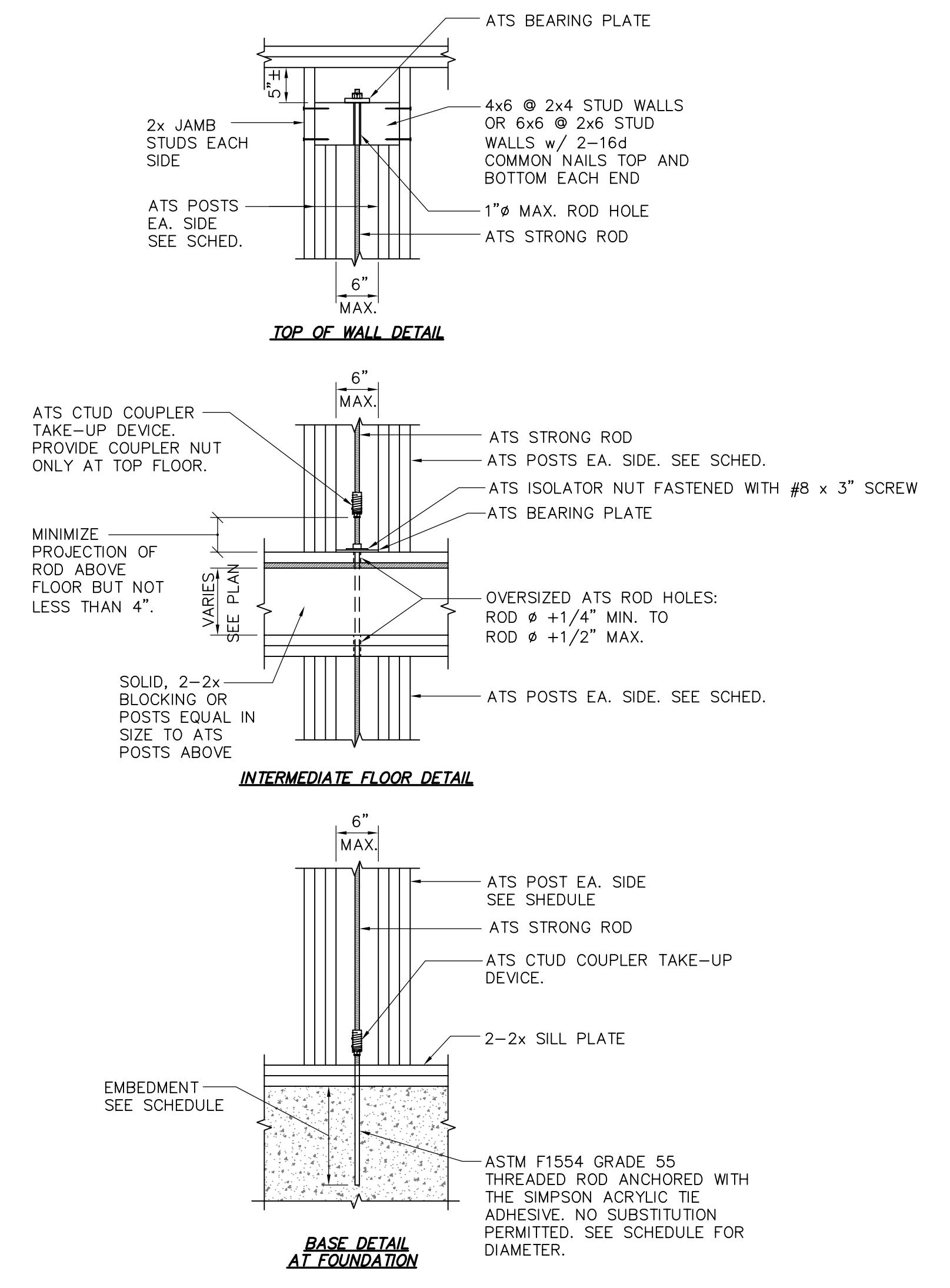

ATS DETAILS

3
S2.6

ANCHOR TIEDOWN SCHEDULE					
TAG	SIMPSON ATS MODEL #	BASE CONNECTION TO FOUNDATION	LEVEL	POSTS IN 2x6 WALL EA. SIDE OF ATS ROD	MODIFICATIONS TO CATALOG RUN
[41]	CTDS41B	ATS-CTUD TO 5/8" ROD WITH 6" MIN. EMBED. TO THICKENED SLAB	4	2-2x6	
			3	2-2x6	
			2	3-2x6	
[50]	CTDS51B	ATS-CTUD TO 7/8" ROD WITH 6" MIN. EMBED. TO THICKENED SLAB	5	2-2x6	
			4	2-2x6	
			3	3-2x6	
			2	3-2x6	
			1	3-2x6	
[51]	CTDS51B	ATS-CTUD TO 7/8" ROD WITH 10 1/2" MIN. EMBED. TO THICKENED SLAB	5	2-2x6	
			4	3-2x6	
			3	6x6	
			2	6x6	
1	6x8				

- NOTES:**
- ATS RUNS ARE "CATALOG CUTS" PER SIMPSON ANCHOR TIEDOWN SYSTEM CATALOG C-ATS07, EFFECTIVE 7/07, U.N.O. SEE CATALOG FOR PRODUCT INFORMATION AND INSTALLATION REQUIREMENTS.
 - SHEAR WALL EDGE FASTEN SHEATHING TO BOTH POSTS AS PER THE WALL TYPE SCHEDULE.
 - SEE ATS TAKE-UP DEVICE INSTALLATION DETAIL FOR ADD'L. REQUIREMENTS.
 - FASTEN BUILT-UP 2x POSTS WITH 10d COMMON WIRE NAILS PLACED AS FOLLOWS:
 - ADJACENT NAILS SHALL BE DRIVEN FROM OPPOSITE SIDES OF THE POST.
 - PLACE NAILS 2 1/2" FROM POST END.
 - PLACE NAILS AT 8" O.C. ALONG POST.
 - PROVIDE 2 ROWS OF NAILS 1 1/2" FROM THE EDGE.

4
S2.6